

Internal dimension cabinet:  
 W=457mm (17 63/64in) x H=255mm (10 3/64in) x D=345mm 345mm (13 37/64in)  
 Internal net volume: 40 L (

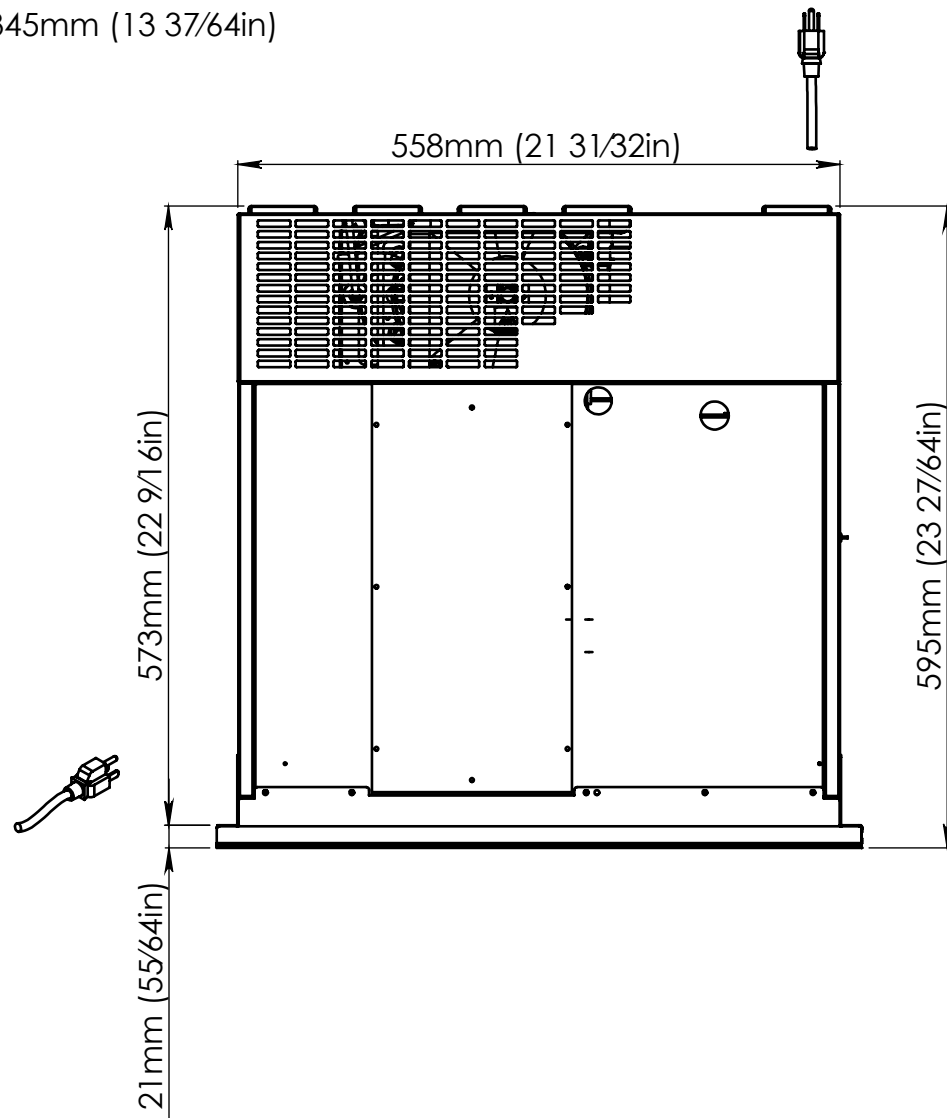

Technical data	
Yeld for blast chilling cycle	3,5kg (7lb)
Yeld for shock freezing cycle	3kg (6lb)
Number of trays	2
Temperature cooling/heating	up to -31 / 185 °F
Voltage	110-120V 1Ph 60Hz
Total rating	780W
Total output	7,42A
Compressor rating	0,33 Hp
Refrigerant type	R290
Refrigerant charge	56gr (1,97oz)
Net cabinet weight	43Kg (94lb)

REV.	DESCRIZIONE MODIFICA	DATE	Verificato da:	Date
05				
04				
03				
02				
01	aggiunto normale 110V	21.04.2022	Buffazi	21.04.2022
00	Emissione	19/02/2016	Dallo Cro.D.	19/02/2016

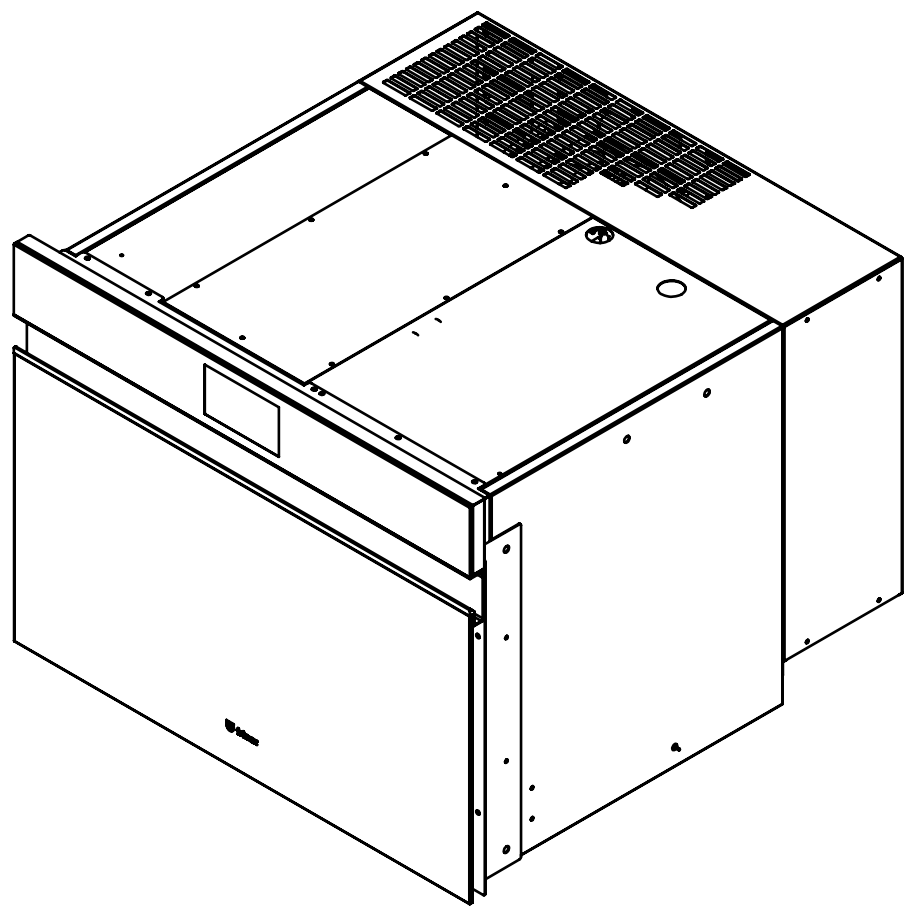

Quote senza indicazione di tolleranza: **grado di precisione ISO 2768-mK**  
 Questo documento è proprietà riservata e non può essere utilizzato o riprodotto senza autorizzazione.

Sviluppo:  
 TRATTAMENTO:

MAT.:  
 PESO: - Kg.

SCALA: **1:7**

DIS. DA: **Fava L.**  
 IL: **19/02/2016**

MODELLO: **Freddy 45 USA ETL**  
 DESCRIZIONE:

CODICE:  
**Freddy 45 USA ETL**